

Thin Film Array Chip Resistor – TFAN Series

Construction

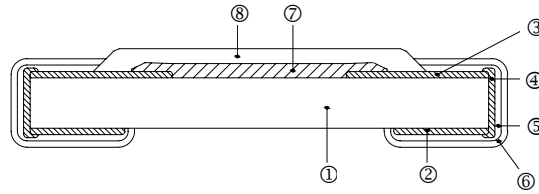
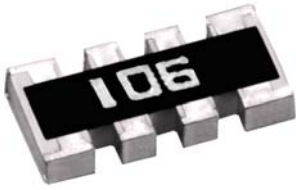

① Alumina Substrate	⑤ Barrier Layer (Ni)
② Bottom Electrode (Ag)	⑥ External Electrode (Sn)
③ Top Electrode (Ag-Pd)	⑦ Resistor Layer (NiCr)
④ Edge Electrode (Ag)	⑧ Overcoat (Epoxy)

Features

- Advanced thin film technology
- Very tight tolerance down to $\pm 0.1\%$
- Extremely low TCR down to $\pm 25\text{PPM}/^\circ\text{C}$
- RoHS compliant component, compatible with lead (Pb)-free

Derating Curve

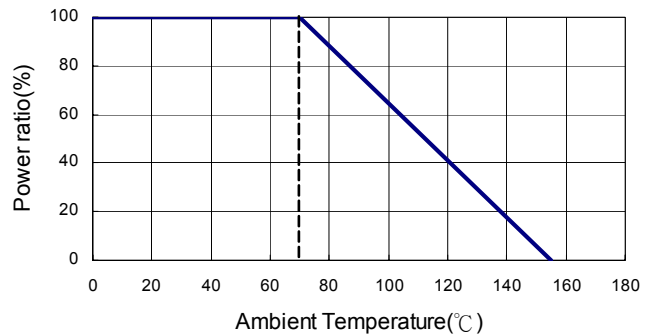

Applications

- Voltage divider
- Feedback circuits
- Signal conditioning

Dimensions

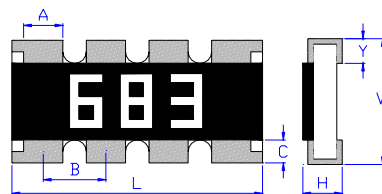

Unit: mm

Type	Number of Resistors	L	W	H	A	B	C	Y	Weight (g) (1000pcs)
TFAN43	4	3.20 \pm 0.15	1.60 \pm 0.15	0.55 \pm 0.10	0.50 \pm 0.15	0.80 \pm 0.05	0.30 \pm 0.15	0.30 \pm 0.15	8.22

Part Numbering

TFAN	43	B	T	C	Y	1001	N
Product Type	Dimensions	Resistance Tolerance	Packaging Code	TCR (PPM/ $^\circ\text{C}$)	Power Rating	Resistance	Marking Code
	43: 0603X4	B: $\pm 0.1\%$ C: $\pm 0.25\%$ D: $\pm 0.5\%$ F: $\pm 1\%$	T: Taping Reel B: Bulk	B: ± 10 N: ± 15 C: ± 25 D: ± 50	: Standard Y: 1/16W	0010: 1 Ω 4R70: 4.7 Ω 1001: 1K Ω 1004: 1M Ω	: Standard Marking for E96 N: No Marking

Standard Electrical Specifications

Item Type	Power Rating at 70°C	Operating Temp. Range	Max. Operating Voltage	Max. Overload Voltage	Number Of Resistors	Resistance Range				TCR (PPM/°C)
						±0.1%	±0.25%	±0.5%	±1%	
TFAN 43	1/16W	-55 ~ +155°C	50V	100V	4	100Ω~33KΩ				±25 ±50

Operating Voltage= $\sqrt{P \cdot R}$ or Max. operating voltage listed above, whichever is lower.

Overload Voltage= $2.5 \cdot \sqrt{P \cdot R}$ or Max. overload voltage listed above, whichever is lower.

Special Specifications

Item Type	Power Rating at 70°C	Operating Temp. Range	Max. Operating Voltage	Max. Overload Voltage	Number Of Resistors	Resistance Range				TCR (PPM/°C)
						±0.1%	±0.25%	±0.5%	±1%	
TFAN 43	1/16W	-55 ~ +155°C	50V	100V	4	100Ω~2KΩ				±10 ±15

Operating Voltage= $\sqrt{P \cdot R}$ or Max. operating voltage listed above, whichever is lower.

Overload Voltage= $2.5 \cdot \sqrt{P \cdot R}$ or Max. overload voltage listed above, whichever is lower.

Environmental Characteristics

Item	Requirement		Test Method
	Tol. ≤ 0.25%	Tol. > 0.25%	
Temperature Coefficient of Resistance (T.C.R.)	As Spec.		MIL-STD-202F Method 304 +25/-55/+25/+125/+25°C
Short Time Overload	ΔR±0.25%	ΔR±0.5%	JIS-C-5201-1 5.5 RCWV*2.5 or Max. overload voltage for 5 seconds
Insulation Resistance	>1000 MΩ		MIL-STD-202F Method 302 Apply 100V _{DC} for 1 minute
Endurance	ΔR±0.25%	ΔR±0.5%	MIL-STD-202F Method 108A 70±2°C, Max. working voltage for 1000 hrs with 1.5 hrs "ON" and 0.5 hrs "OFF"
Damp Heat with Load	ΔR±0.25%	ΔR±0.5%	MIL-STD-202F Method 103B 40±2°C, 90~95% R.H. Max. working voltage for 1000 hrs with 1.5 hrs "ON" and 0.5 hrs "OFF"
Bending Strength	ΔR±0.25%	ΔR±0.5%	JIS-C-5201-1 6.1.4 Bending amplitude 3 mm for 10 seconds
Solderability	95% min. coverage		MIL-STD-202F Method 208H 245±5°C for 3 seconds
Resistance to Soldering Heat	ΔR±0.25%	ΔR±0.5%	MIL-STD-202F Method 210E 260±5°C for 10 seconds
Dielectric Withstand Voltage	100V		MIL-STD-202F Method 301 Max. overload voltage for 1 minute
Thermal Shock	ΔR±0.25%	ΔR±0.5%	MIL-STD-202F Method 107G -55°C ~150°C, 100 cycles
Low Temperature Operation	ΔR±0.25%	ΔR±0.5%	JIS-C-5201-1 7.1 1 hour, -65°C, followed by 45 minutes of RCWV

Storage Temperature: 25±3°C; Humidity < 80%RH

Equivalent Circuit Diagram

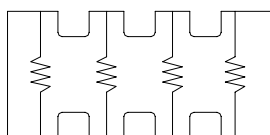

TFAN

■ Packaging

Reel Specifications & Packaging Quantity

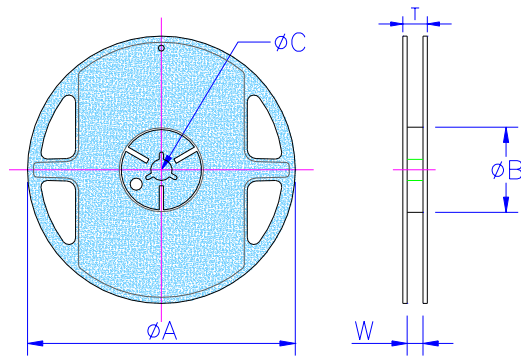

Unit: mm

Type	Packaging Quantity	Tape Width	Reel Diameter	ΦA	ΦB	ΦC	W	T
TFAN 43	Paper	5K	7 inch	178.5±1.5	60 ^{+1/-0}	13.0±0.2	9.0±0.5	12.5±0.5

Paper Tape Specifications

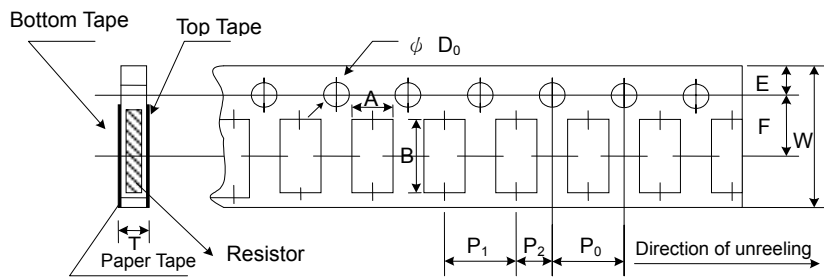

Unit: mm

Type	A	B	W	E	F	P_0	P_1	P_2	ΦD_0	T
TFAN 43	1.95±0.10	3.50±0.10	8.0±0.20	1.75±0.10	3.5±0.05	4.0±0.10	4.0±0.05	2.0±0.05	1.5 ^{+0.1/-0}	0.85±0.10

■ Recommend Land Pattern

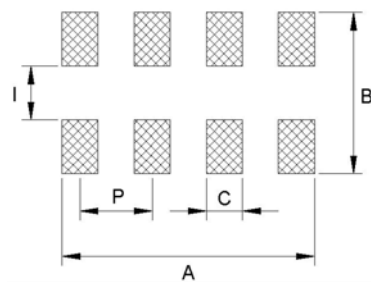

Unit: mm

Type	A	B	C	C1	I	I1	P	P1
TFAN 43	2.85	3.10	0.45	--	0.80	--	0.80	--